



CUSTOM POWDER SYSTEMS.
THE CONTAINMENT COMPANY



**INTEGRATED
CONTAINMENT
SYSTEMS.**



WHO

Custom Powder Systems/ Integrated Containment Systems (CPS/ICS) is a 17-year old bright metals custom fabrication company. CPS/ICS is a fully integrated company that can assist from conceptual design through final installation. During our 17-year history CPS/ICS has continually worked with companies in the following industries.

- Food
- Additive Manufacturing
- Pharmaceutical Parenteral
- Chemical
- Nutraceutical
- Pharmaceutical OTC
- Powdered Metals
- Battery Production
- Pharmaceutical Ethical

WHAT

CPS/ICS designs and fabricates situation-specific systems for Dry Material Handling/ Process/ Containment Equipment that is fully-integrated for your current systems. Our team of engineers and craftsmen are in business to find solutions for the production challenges you are experiencing today, while being flexible enough for whatever tomorrow brings.

WHEN

At our core, our employees are problem solvers. If your you need help with one of these issues pick up the phone and let us help find the best solution you.

- Operator Protection
- Contamination issues
- Segregation of blended Materials
- Product Protection
- Low Yields
- Cleaning Systems
- Discharge Spillage
- Inconsistent Blending
- Lifting Issues

WHERE

All of our equipment is proudly designed and built in Springfield Missouri, while having a global foot print. Our centralized location allows us to promptly respond to site and service needs in the United States and North America.

WHY

- 200+ Combined Years Experience
- Flexibility
- Vertically Integrated
- Diverse Product Line
- Strong client relationships
- Custom Solutions

2715 N Airport Commerce Ave. Springfield, MO 65803
417-868-8002

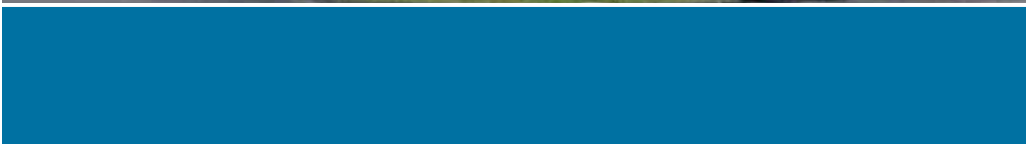



Hopper Bottom IBC

Intermediate bulk containers (IBC), also known as Bins, Hoppers, Vessels, Totes, and Containers, are the centerpiece of our handling equipment, and a key component in ensuring a safe work environment. Our IBCs can be designed to work with the systems that you have in place or can become the basis for an entirely new production method.

We offer a wide variety of IBCs including but not limited to:

- Hopper Bottom
- Cone Top
- Side Door
- Double Cone
- Open Top
- Tablet
- V-Shell



Our IBCs can also be designed to scale with your business from R&D Sizes to large scale production

Benefits of IBC blending are:

- Total product containment
- Dual action low shear blending
- Reduced risk of segregation
- No required cleaning between batches
- No product cross contamination risk
- Increased process flexibility
- Ease of automation
- 97.5% or greater blend uniformity
- Reduced blend times compared to other blender types

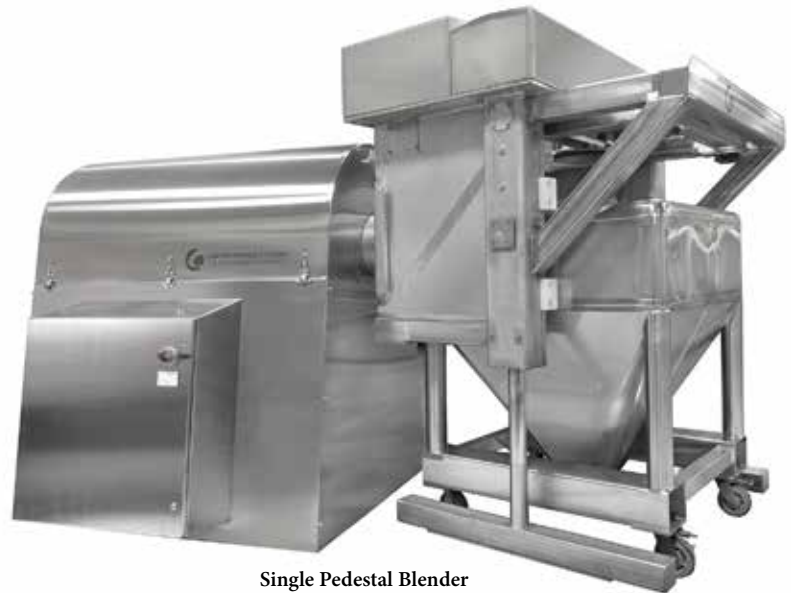

Single Pedestal Blender



Drum Massager

The CPS Drum Massager breaks-up hardened material in drums, pails and boxes so they can be emptied without chipping and pounding. Both fully automatic and manual versions are available to suit your needs.



CUSTOM POWDER SYSTEMS.
THE CONTAINMENT COMPANY



**INTEGRATED
CONTAINMENT
SYSTEMS.**

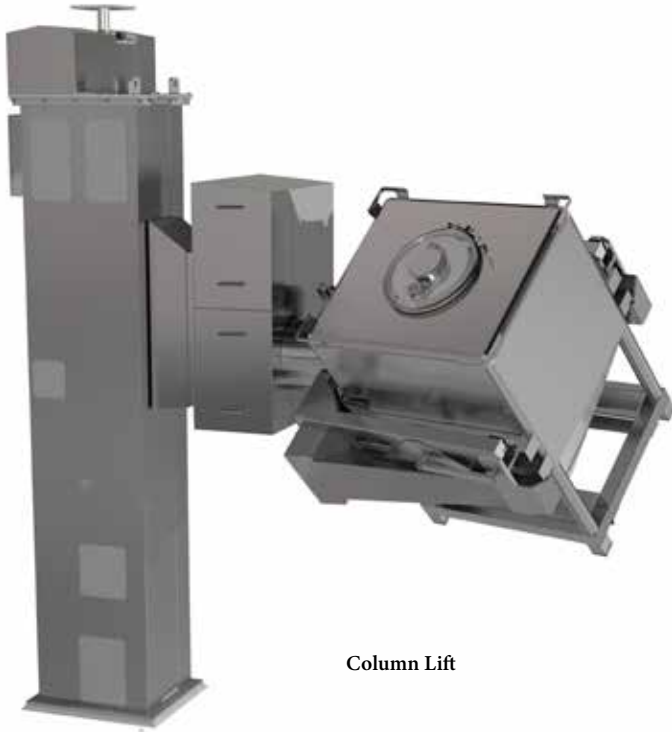

Column Lift

CPS column lifts offer the ability to accurately lift and place IBCs of all sizes. This, coupled with our wide variety of receivers, make our lifts true workhorses.

Features Include:

- GLIDE SEAL PLUS
- AccuDok
- JamDetection
- ASME B20.1 safety compliant
- Free Standing design

Tilt and Docking Stations are key components in our line of equipment to ensure a contained and uniform transfer to and from an IBC.

- Jet Wash
- EZ-Down
- FLOW-Assist
- RVA



Transfer Station



IBC Wash Station

CPS washing equipment prepares the IBCs for a fresh start into the beginning of a new batch. From manual to completely automated we have a solution to fit your needs.

- Recycle water for reduced operation cost
- High pressure / low volume system for difficult cleaning applications.
- High volume / low pressure for water soluble applications



Down Flow Booth

Down Flow Booths are becoming common place not only in the pharmaceutical industry. We are seeing more and more used for the food and chemical industries along with inquiries from many others.

Features Include:

- Airsweep Technology
- HEPA and ULPA Filters
- Explosion Proof and Solvent Systems available
- 12 Standard Sizes and custom options
- Exposure levels of 50 to 100ug/m³

Isolators allow your operators to safely and comfortably work full shift without the need to wear cumbersome PPE. Whether your products are toxic, aseptic or aseptic/toxic we have a solution uniquely developed to protect your workers, your product and promote reliable process flow.

- Ergo positioning
- Integrated PLC Controller



Isolator

Restrictive Access Barrier Systems (RABS) can quickly convert a procedural-based risky open clean-room process into a controlled environment. RABS are excellent solution to update existing aseptic process.



RABS

Lyophilizer Carts, also known as HEPA carts, can instantly solve the regulatory issue of the transport of unstoppered vials though unclassified or lower grade hallways.



Lyo Cart



CUSTOM POWDER SYSTEMS.
THE CONTAINMENT COMPANY



**INTEGRATED
CONTAINMENT
SYSTEMS.**



Anti-Segregation Discharge



IBC Lift



Weigh Dispense System



Column Lift With Drum Inverter

Proudly Made In Springfield Missouri



Our business philosophy is simple, to design our products specifically to the client's application. We have standard designs but seldom build a standard unit. This is the 'Custom' in Custom Powder Systems.

- We Design, Manufacture, Integrate and Test all containment and material handling systems in Springfield Missouri. We are one of a few suppliers in this field that do not rely on major subcontracting.
- Our Control Systems are designed and programmed by our In-house Automation Group. All UL and non-UL panels are built, installed and tested by our in-house UL508A certified panel shop.
- Our highly experienced Technical Services Group can provide same day support for any emergency situations should they arise.
- The CPS Engineering Group uses Inventor 3-D Modeling software allowing customers to virtually 'see' the components and systems before we build them in our bright metals only facility.
- ISO modeled Quality Assurance procedures guide our experienced team as we adhere to current Good Manufacturing Practices (cGMP) and Good Automation Manufacturing Practices (GAMP). Projects may be GAMP compliant if required.

2715 N Airport Commerce Ave. Springfield, MO 65803

417-868-8002

The sales team at Custom Powder Systems is eager to assist you throughout the entire buying process. We will work with you from concept to completion making sure that your experience with CPS is as smooth and enjoyable as possible. It is our job to make your job easier! For more information about our products or to get your quote started today please give us a call.



CUSTOM POWDER SYSTEMS.
THE CONTAINMENT COMPANY



**INTEGRATED
CONTAINMENT
SYSTEMS.**